

# Cornerstone Bible Church

## An Existential Dilemma

(Romans 7:1-25)

Survey of Romans part 21

Edwin Gonzalez

February 25, 2018

## Our Goal with Romans

“To help us fix the short circuit.”

Not this one...

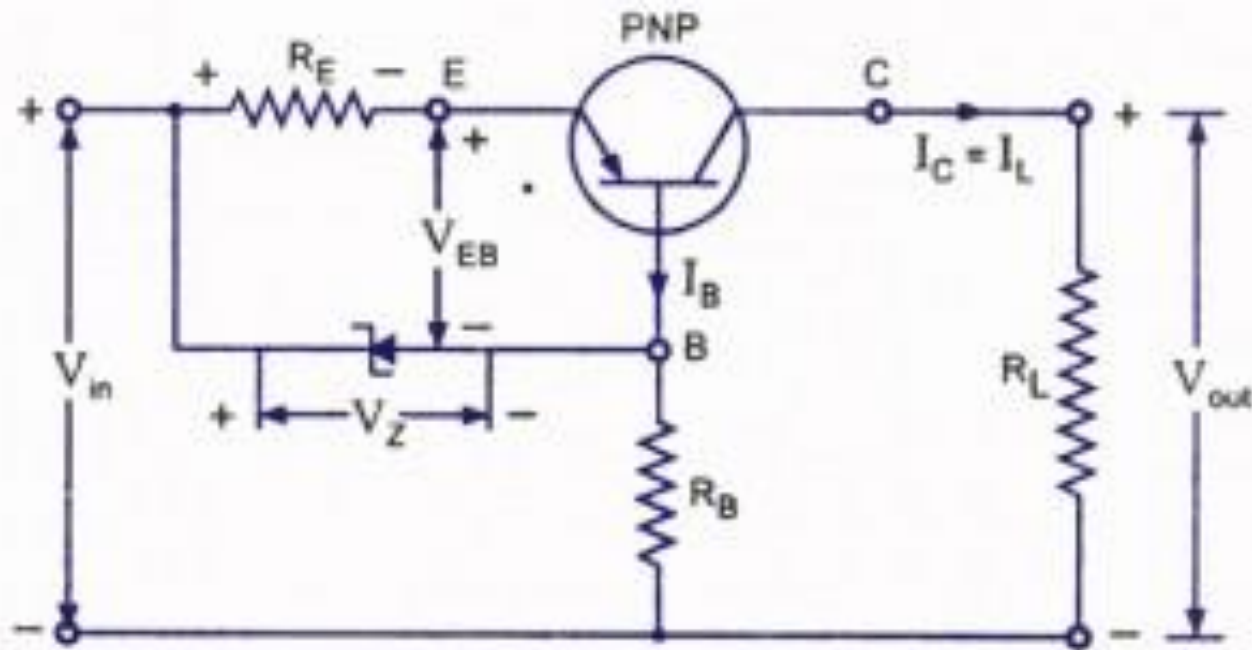

*Transistor Current Regulator*

## Our Goal with Romans

“To help us fix the short circuit.” ... but this one.

The Gospel of SOLA FIDE,  
SOLUS CHRISTUS

The Law “Do this and you  
shall live.”

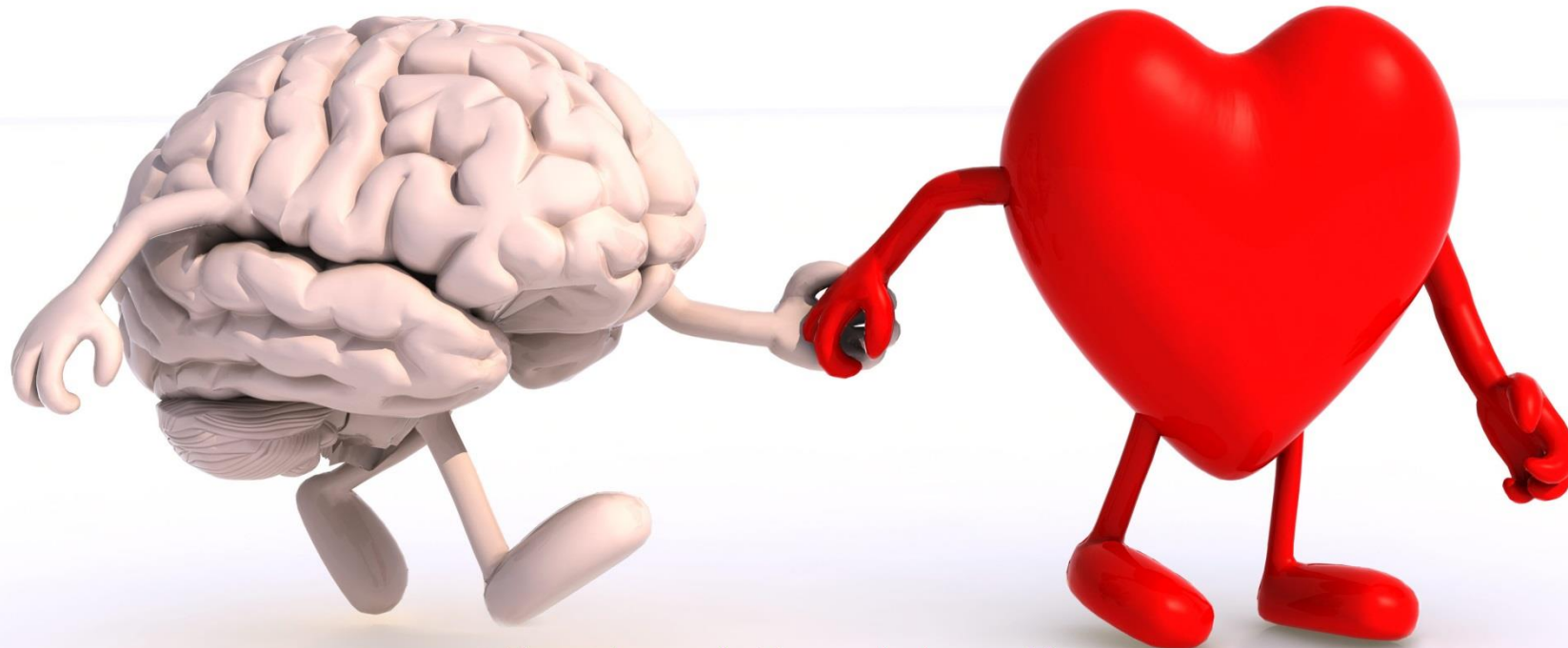

Head and Heart together

[www.aPlaceOf.Love](http://www.aPlaceOf.Love)

I will walk before the Lord in the  
land of the living Psalm 116:9

“Jesus paid it all, all to  
Him I owe”

## Introduction / illustrations:

- An addict runs to the substance or behavior that destroys him or her.

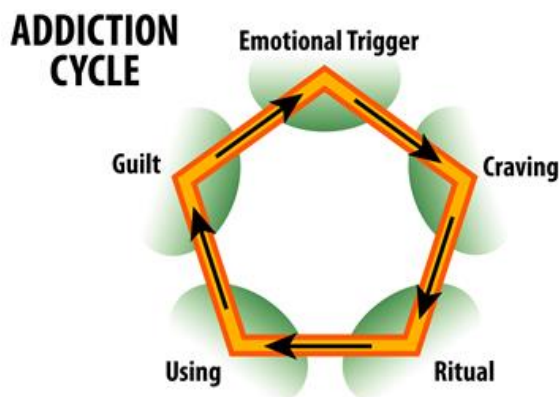

- Slaves in America, after being liberated, did not know what to do or where to go, many remained in their plantations.
- Some Japanese soldiers in remote posts had not learned that WWII had ended, some POW were still imprisoned.

## Introduction / illustrations:

- People released from cultic, totalitarian, manipulative and enslaving leaders (abused women), go back to the place or person who enslaved them.

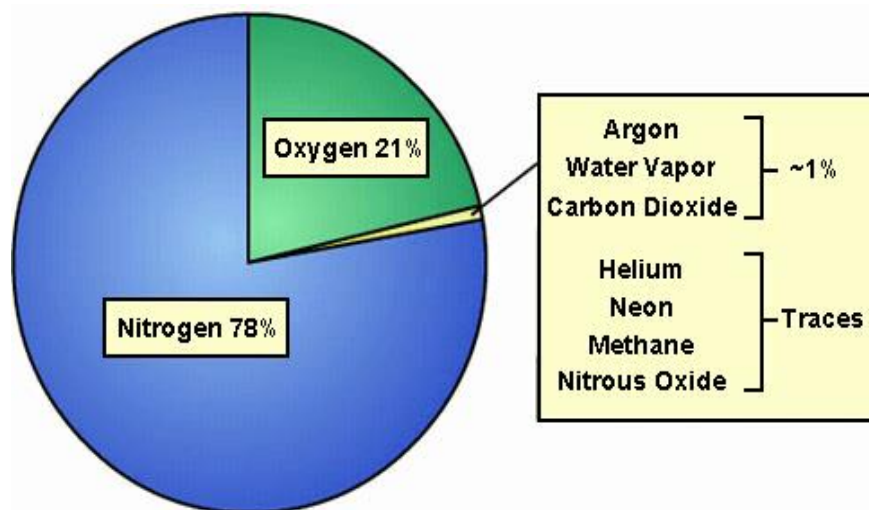

**Breathing:** We are never in a 100% oxygen environment. Not here on earth. We may breathe more or less pure air, but we always breathe mixed air.

- These illustrations are not an exact depiction of what Romans 7 describes, but they may paint a picture similar to what happens to a believer with respect to sinful habits and behavior, even after having been released by Christ.

***The Tension to Understand Romans 6, 7 & 8***

*SIMMUL JUSTUS ET PECCATOR*

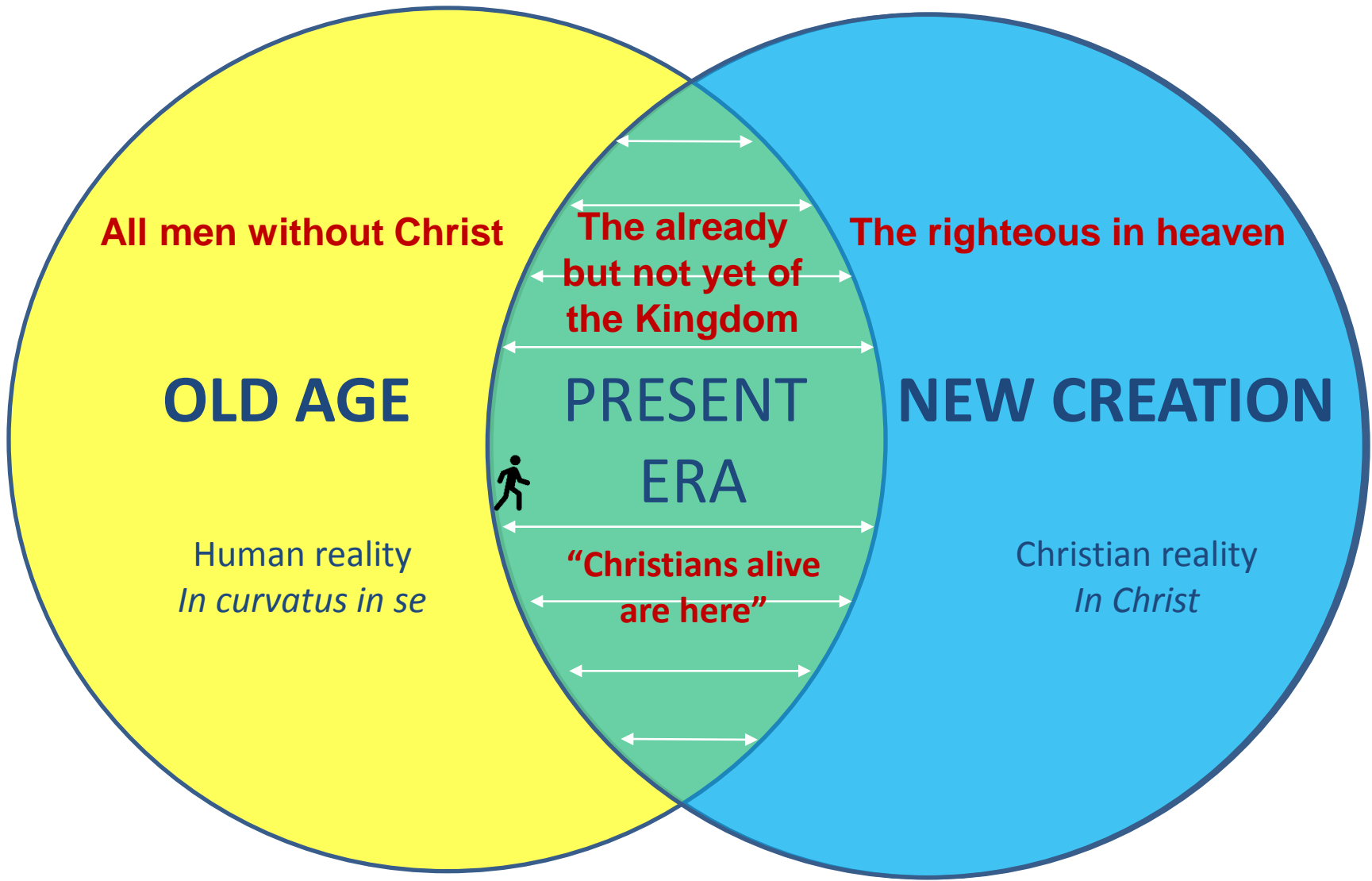

## ***The Believer's Existential Dilemma***

- We are new creatures in Christ. 2 Corinthians 5:17
- We have been made partakers of the Divine Nature 2 Peter 1:4
- We are a new self, in the likeness of God, created in righteousness and holiness of the truth Ephesians 4:24
- **But, we still live in a body of flesh!** We have not been transformed yet! cf. Romans 8
- We live between two worlds.

**Today's Text:** Romans 7

### **Outline:**

- a) An illustration 1-6
- b) An explanation 7-14
- c) An affirmation 15-25

**REMINDER: DID  
PAUL HAVE AN  
OUTLINE FOR  
CHAPTER 7?**

a) **An illustration:** the relationship between the Christian and the Law. 1-6

<sup>1</sup> “Or do you not know, brothers—for I am speaking to those who know the law—that the law is binding on a person only as long as he lives?

<sup>2</sup> For a married woman is bound by law to her husband while he lives, but if her husband dies she is released from the law of marriage.

<sup>3</sup> Accordingly, she will be called an adulteress if she lives with another man while her husband is alive. But if her husband dies, she is free from that law, and if she marries another man she is not an adulteress.

<sup>4</sup> Likewise, my brothers, you also have died to the law through the body of Christ, so that you may belong to another, to him who has been raised from the dead, in order that we may bear fruit for God.

<sup>5</sup> For while we were living in the flesh, our sinful passions, aroused by the law, were at work in our members to bear fruit for death.

<sup>6</sup> But now we are released from the law, having died to that which held us captive, so that we serve in the new way of the Spirit and not in the old way of the written code.”



a) **An illustration:** the relationship between the Christian and the Law. 1-6

1. The bond of marriage: dissolved by death.
2. Jesus annulled the yoke of the Law against us at the cross, then He married us.
3. Therefore, the Law has no longer power to bind us. We have been espoused to Christ!
  - The Law cannot curse and condemn us. We are married to a new husband!
  - Our new reality is described by verse 6: “But now we are released from the law, having died to that which held us captive, so that **we serve in the new way of the Spirit** and not in the old way of the written code.”

a) **An illustration:** the relationship between the Christian and the Law. 1-6

- We now keep the Law in the Spirit. Paul elaborates this further in the following chapter.
- The Gospel does not release us from obeying. Jesus said: “Why do you call me Lord, Lord and do not do what I say?” Luke 6:46
- However; obedience in the Spirit, as free people, is very different from the obedience of slavery. Cf 6:17 “**you became obedient from the heart to that form of teaching to which you were committed.**” Illust: (“loving” boss versus “terrorizing” boss)
- This is only possible, because we have been released from the bondage of the Law, because we died to sin.
- **What is this?**



**b) An explanation:** of the relationship between The Law and Sin. 7-14

<sup>7</sup> “What then shall we say? That the law is sin? By no means! Yet if it had not been for the law, I would not have known sin. For I would not have known what it is to covet if the law had not said, “You shall not covet.”

<sup>8</sup> But sin, seizing an opportunity through the commandment, produced in me all kinds of covetousness. For apart from the law, sin lies dead.

<sup>9</sup> I was once alive apart from the law, but when the commandment came, sin came alive and I died.

<sup>10</sup> The very commandment that promised life proved to be death to me.

<sup>11</sup> For sin, seizing an opportunity through the commandment, deceived me and through it killed me.

<sup>12</sup> So the law is holy, and the commandment is holy and righteous and good.

<sup>13</sup> Did that which is good, then, bring death to me? By no means! It was sin, producing death in me through what is good, in order that sin might be shown to be sin, and through the commandment might become sinful beyond measure.”

**b) An explanation:** of the relationship between The Law and Sin. 7-14

- **The problem is not with the Law.** The commandment is good.
- The Law points to and reflects the heart and character of God. It is God's will and desire. There's nothing wrong with the Law. Psalm 19:7 "The Law of the Lord is perfect!"
- **If the problem is not with the Law, what is it?**  
The problem is SIN!



=> **A not so good illustration:** a perfectly well functioning machine with a bad operator.

**b) An explanation:** of the relationship between The Law and Sin. 7-14

- **The Law is good, because God's will is good!** But, we are still in a body of flesh, the flesh cannot and wills not to submit to God's Law.
- **The evil of sin is such**, that it uses something morally perfect as the Law, to manifest itself.
- The Law is what gives traction to sin.
- Sin without the Law is like a powerful Jet Engine without air to pull and push



320,924 lbs of thrust on earth ...

... It could not move on the moon

**b) An explanation:** of the relationship between The Law and Sin. 7-14

- **Paul uses the example of coveting!** We could fit any example here.
- ✓ Coveting is the opposite of love
- ✓ Do you covet your beloved joy and achievements?
- ✓ *Normally, we rejoice in our children's success and joy.*
- ✓ Sin is like taking a poison, that warps the psyche, and fills us with rage, envy and lust at others' success.

**b) An explanation:** of the relationship between The Law and Sin. 7-14

**Theologically:** If it were not for sin, God would not have had to issue the commandment, “thou shalt not covet”.

That commandment had no meaning for Adam and Eve in the garden.

What would they covet if everything was good, perfect and theirs?

When sin entered the world, coveting arrived, hence the commandment: “thou shalt not covet”.

**b) An explanation:** of the relationship between The Law and Sin. 7-14

**Theologically**: If it were not for sin, God would not have had to issue the commandment, “thou shalt not covet”.

- We may covet the ministerial success of Vineyard.
- We may covet the good marriage of our neighbors.
- We may covet the nice jobs of our peers, if our jobs stink.
- We may covet the success of our companions.

Why? Because sin, to show its sinfulness, takes something that is good – The Law - and makes us do the opposite.

If you do not covet, congratulations, you beat Paul, or perhaps you are “alive” as Paul was before understanding the commandment. (Will explain later)



**END**